

flanged foot inserts for round & square tubing



TM



FLANGED ADJUSTABLE FOOT INSERTS

For Round or Square Tubing or Pipe

Available in:

- Stainless Steel Clad
- Nickel Plated Zamak
- Available with or without Mounting Holes
- Certain Models Furnished Complete with Posi-Grip to Lock Foot to Tube

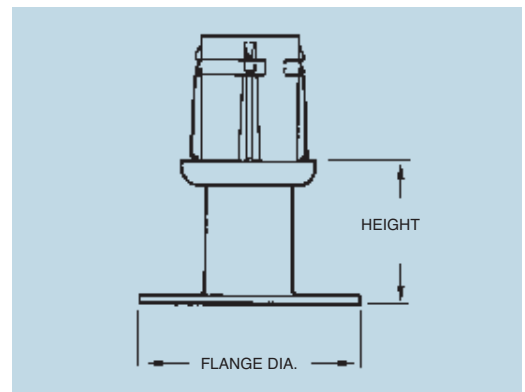

flanged foot inserts for round & square tubing



FLANGED ADJUSTABLE FOOT INSERTS FOR ROUND OR SQUARE TUBING OR PIPE

APPLICATION	FLANGE DESCRIPTION	HEIGHT	ADJ.	MODEL NO.	LOAD RATING Lbs/Ft (Kg/mm)	REF.
1" (25mm) SQUARE TUBING 16 GA. (1.5mm) & 18 GA. (1.2mm)	1-3/16"(30mm) DIA. NICKEL PLATED ZAMAK	3/4" (17.5mm)	1/2" (12mm)	A14-0224-C	1200 (550)	A
1-1/4" (32mm) SQUARE TUBING 16 GA. (1.5mm) OR 18 GA. (1.2mm)	2-1/8" (54mm) NICKEL PLATED ZAMAK	1-3/8" (35mm)	1" (25mm)	A14-0424-C	2000 (900)	B
1-1/4" I.P.S. PIPE OR 1-1/2" (38mm) O.D. ROUND TUBING 16 GA. (1.5mm)	3-1/2"(89mm) DIA. S/S WITH MOUNTING HOLES**	1-1/2" (38mm)	1-1/8" (28mm)	A10-0654-C	2000 (900)	D*
1-1/2" (38mm) SQUARE TUBING 16 GA. (1.5mm) OR 18 GA. (1.2mm)	3-1/2"(89mm) DIA. S/S NO MOUNTING HOLES	1-1/2" (38mm)	1-1/8" (28mm)	A14-0653-C	2000 (900)	C*
	3-1/2"(89mm) DIA. S/S WITH MOUNTING HOLES**	1-1/2" (38mm)	1-1/8" (28mm)	A14-0654-C	2000 (900)	C*
1-5/8" (41mm) O.D. ROUND TUBING FOR MARINE APPLICATION 16 GA. (1.5mm)	2"(50mm) DIA. S/S NO MOUNTING HOLES	1-1/2" (38mm)	1-1/8" (28mm)	A10-9904-C	2000 (900)	E
1-5/8" (41mm) O.D. ROUND TUBING 16 GA. (1.5mm)	3-1/2"(89mm) DIA. S/S NO MOUNTING HOLES	1-1/2" (38mm)	1-1/8" (28mm)	A10-0853-C	2000 (900)	D
	3-1/2"(89mm) DIA. S/S WITH MOUNTING HOLES**	1-1/2" (38mm)	1-1/8" (28mm)	A10-0854-C	2000 (900)	D*
2" (50mm) O.D. ROUND TUBING 16 GA. (1.5mm)	3-1/2"(89mm) DIA. S/S WITH MOUNTING HOLES**	1" (25mm)	2" (50mm)	A11-0854-C	2300 (1040)	F*
2" (50mm) SQUARE TUBING 16 GA. (1.5mm) OR 18 GA. (1.2mm)	3-1/2"(89mm) DIA. S/S WITH MOUNTING HOLES**	1" (25mm)	2" (50mm)	A15-0854-C	2300 (1040)	G*

* FLANGED FOOT MODELS HAVE 12 GA. (2.6mm) STAINLESS STEEL FLANGE WITH A #4 SATIN FINISH.

**PROVIDED WITH (2) 11/32" (9mm) DIA. MOUNTING HOLES, SPACED 2-1/2"(63mm) O.C.