

CROSS BRACE FITTINGS

**FOR 1-1/2" (38mm) O.D. LEGS
and 1-5/8" (41mm) O.D. LEGS**



Designed to mate 1-1/2" (38mm) and 1-5/8" (41mm) O.D. vertical legs and 1-1/4" (32mm) O.D. horizontal cross rails. These die cast aluminum CROSS BRACE FITTINGS eliminate notching, welding and polishing. Ideal for knock-down shipping.

QUICK CORNER BRACKETS

**FOR ADJUSTABLE UNDERSHELVES
FOR 1-1/2" (38mm) O.D. LEGS
and 1-5/8" (41mm) O.D. LEGS**

QUICK CORNER BRACKETS are pre-finished die cast aluminum components. They are easily fastened to pre-notched sheet metal undershelves to provide strong, secure, rigid undershelf support assemblies. Adjusting screws are provided for setting the undershelf to any desired height. Welding, grinding and polishing is eliminated and knock-down shipping is facilitated. Corner and center brackets are designed for either 1-1/2" (38mm) or 1-5/8" (41mm), O.D. tubing. They tightly lock into simple notched sheet metal openings. Diagrams are provided with instructions.

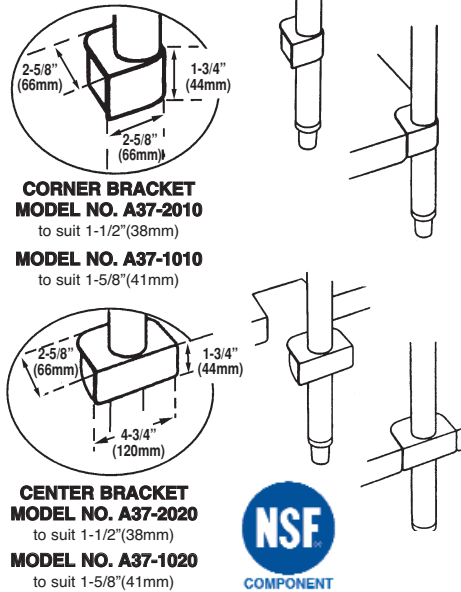
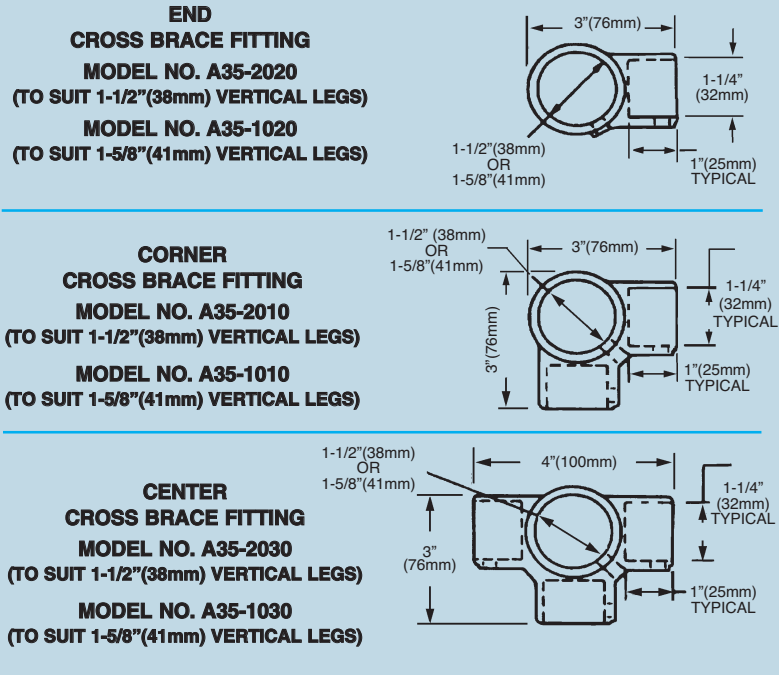

NSF STANDARDS GOVERNING THE USE OF SET SCREWS IN NON-FOOD ZONES REQUIRES THE PLUGGING OF THE HEX SOCKET HOLE AFTER FINAL ASSEMBLY AND TIGHTENING. THIS MAY BE ACCOMPLISHED BY APPLYING A HARDENING TYPE SILICONE SEALANT OR THE USE OF A HOLE PLUG. STANDARD N.S.F. TYPE PUSH-IN PLASTIC HOLE PLUGS ARE AVAILABLE...SPECIFY A10-0020 WHEN ORDERING, SEE PAGE A24.